

DATE
January 20, 2009
CAT. #:

OUTLINE DIMENSIONS
3-PHASE INDUCTION MOTOR

MOTOR TYPE:
AEHH8B-CF
FRAME NO. 284TSC

Pole	HP	kW	Hz	VOLT	Syn.Speed r/min(rpm)
2					

Ins	Rating	Dimension in	Approx Weight	Bearings
F	CONT.	inches	430 LBS	DE: 6311ZC3 NDE: 6310ZC3

Totally Enclosed Fan Cooled Type. Squirrel-cage Rotor.

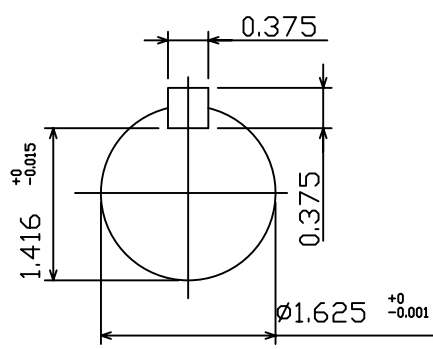
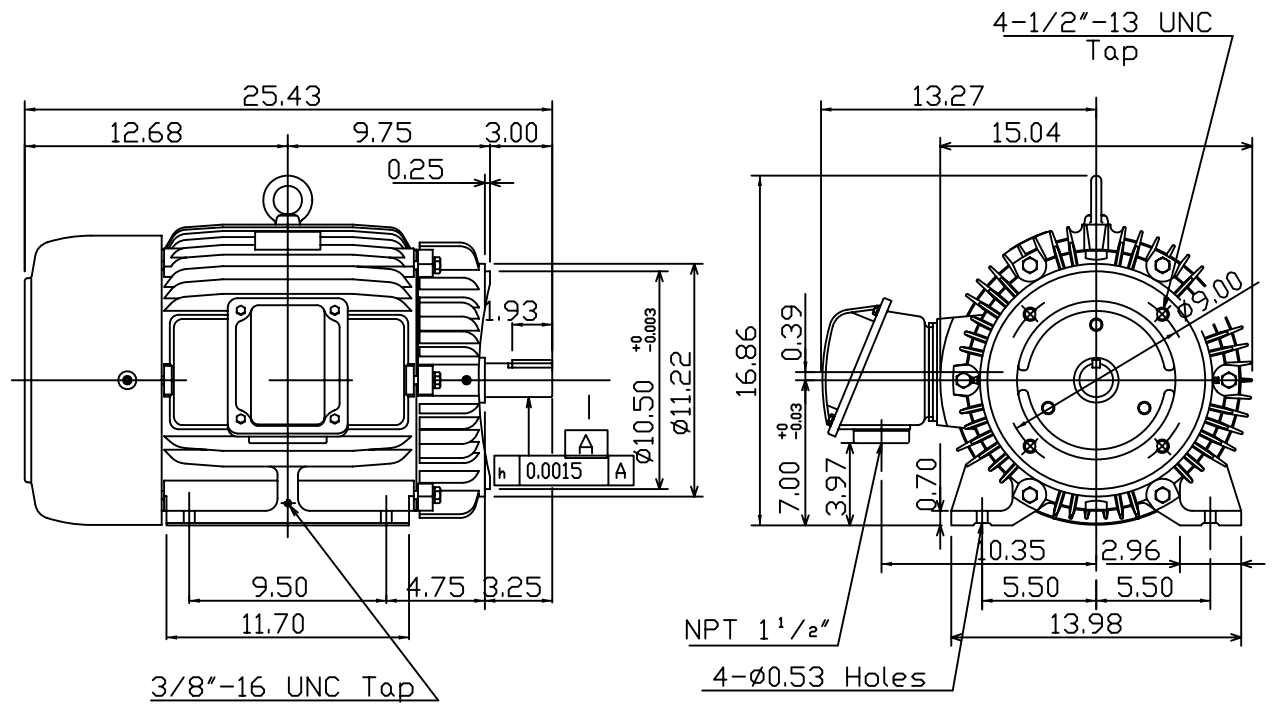

Note:
1. Motor Vibration:10?
2. Inpro/Seal in Both End Brackets

① 01.03.09

DWN.	???????	01 19 05
CHKD.	???????	01 02 09
APPD.	???????	01 02 09



DWG NO.
31049M627401